



Special City Council Meeting

5:00 p.m., Tuesday, January 7, 2025
 City of Isle of Palms, South Carolina

Agenda

- 1. Introduction of the meeting** – Call the special meeting to order and acknowledge that the press and the public were duly notified of the meeting in accordance with the Freedom of Information Act.

- 2. Mayor’s Opening Remarks**

- 3. Purpose**
 - a. Announcements of nominations and appointments to standing Committees for 2025
 - Administration – John Bogosian, Jimmy Ward, Phillip Pounds (Ashley Carroll to replace Phillip Pounds after City Administrator role is filled)
 - Public Safety – John Bogosian, Jan Anderson, Rusty Streetman
 - Public Services and Facilities – Katie Miars, Scott Pierce, Blair Hahn
 - b. Announcement of appointment to CARTA Board of Directors – Jimmy Ward
 - c. Announcement of appointment to Charleston Visitors Bureau Board of Directors – Rusty Streetman
 - d. Announcement of appointment to the Charleston, Berkeley, Dorchester Council of Governments – Jan Anderson
 - e. Announcement of appointment to the Environmental Advisory Committee – Katie Miars
 - f. Announcement of appointments to Boards and Commissions

Planning Commission (2-year Terms) Terms expire 12/31/2026	Environmental Advisory Committee (3-year Terms) Terms expire 12/31/2027	Board of Zoning Appeals (3-year Terms) Terms expire 12/31/2027
David Cohen	Mary Pringle	Suzy Wheeler
Tim Ahmuty	Cindy Marrs	Glenn Thornburg
Sandy Stone	Eric Cicora	
	Sean Popson	

- g. Consideration of award of contract to Truluck Construction, Inc. for the construction of an emergency access path through the Charleston County Park for \$328,436 [FY25 Budget, Beach Preservation Fund, \$250,000]

4. Executive Session – In accordance with S.C. Code Ann. 30-4-70(a)(1) to discuss employment matters- specifically the appointment/compensation of Interim City Administrator. Council may take action following Executive Session.

5. Adjournment

City of Isle of Palms, SC
Request for Bids 2024-12
County Park Emergency Access

Bid Opening - 2:00 p.m., December 20, 2024

Douglas Kerr announced the sealed bid opening of RFB 2024-12. The RFB was advertised in accordance with the City's Procurement Code.

Bids Received:

Bidder	Base Bid
IPW Construction, LLC	\$ 979,000
Truluck Construction Inc.	\$ 328,436
MedPro Systems, LLC	\$ 364,588
Icon Contracting, LLC	\$ 399,255

The bids will be evaluated for accuracy and compliance with the specifications defined in the RFB. A recommendation for award of a contract will be made to City Council.

BID FORM

BID OF: Truluck Construction Inc.

(Contractor)

BID TO: The City of Isle of Palms

(Owner)

PROJECT NAME: County Park Emergency Access

PROJECT NUMBER: RFB 2024-12

BID DATE: 12/20/24

BASE BID AGREEMENT

The undersigned, having examined all the Bidding Documents, including all Addendum(a) as follows:

Plans from Davis and Floyd dated September 2024

shall execute the entire Work in the Bidding Documents described as the Base Bid for the lump sum of:

Three Hundred twenty eight thousand, four hundred thirty six dollars and 90/100 Dollars

BID AMOUNT (all work) \$ 328,436.90



ITEMIZED COSTS (each item should be included in the BASE BID amount)

1. All demolition, site preparation grading and compacting.
\$42,040.00 Cost
2. Installation of electrical and irrigation conduit.
\$9,500.00 Cost
3. Total Turfstone installation including base, preparation, and edging.
\$64,082.00 Cost
4. Total concrete installation including base and preparation.
\$37,104.00 Cost
5. All fencing and gate installation.
\$50,946.00 Cost
6. All drainage work outside of grading (which is included in 1. above).
\$9,246.00 Cost
7. All landscaping installation.
\$29,400.00 Cost
8. All cladder bridge installation (150'x10').
\$53,904.00 Cost
9. All other miscellaneous work.
\$32,213.00 Cost

TOTAL BASE BID (sum of all lines above) \$328,436.90

AIA Document A310™ – 2010

Bid Bond

CONTRACTOR:

(Name, legal status and address)
Truluck Construction, Inc.
1012-A St. Andrews Boulevard
Charleston, SC 29407

SURETY:

(Name, legal status and principal place of business)
Merchants Bonding Company (Mutual)
P.O. Box 14498
Des Moines, IA 50306-3498

OWNER:

(Name, legal status and address)
City of Isle of Palms
1207 Palm Boulevard
Isle of Palms, SC 29451

BOND AMOUNT: Five Percent (5%) of Amount of Bid

PROJECT:

(Name, location or address, and Project number, if any)
County Park Emergency Access

Project Number, if any:
2024-12

This document has important legal consequences. Consultation with an attorney is encouraged with respect to its completion or modification.

Any singular reference to Contractor, Surety, Owner or other party shall be considered plural where applicable.

The Contractor and Surety are bound to the Owner in the amount set forth above, for the payment of which the Contractor and Surety bind themselves, their heirs, executors, administrators, successors and assigns, jointly and severally, as provided herein. The conditions of this Bond are such that if the Owner accepts the bid of the Contractor within the time specified in the bid documents, or within such time period as may be agreed to by the Owner and Contractor, and the Contractor either (1) enters into a contract with the Owner in accordance with the terms of such bid, and gives such bond or bonds as may be specified in the bidding or Contract Documents, with a surety admitted in the jurisdiction of the Project and otherwise acceptable to the Owner, for the faithful performance of such Contract and for the prompt payment of labor and material furnished in the prosecution thereof; or (2) pays to the Owner the difference, not to exceed the amount of this Bond, between the amount specified in said bid and such larger amount for which the Owner may in good faith contract with another party to perform the work covered by said bid, then this obligation shall be null and void, otherwise to remain in full force and effect. The Surety hereby waives any notice of an agreement between the Owner and Contractor to extend the time in which the Owner may accept the bid. Waiver of notice by the Surety shall not apply to any extension exceeding sixty (60) days in the aggregate beyond the time for acceptance of bids specified in the bid documents, and the Owner and Contractor shall obtain the Surety's consent for an extension beyond sixty (60) days.

If this Bond is issued in connection with a subcontractor's bid to a Contractor, the term Contractor in this Bond shall be deemed to be Subcontractor and the term Owner shall be deemed to be Contractor.

When this Bond has been furnished to comply with a statutory or other legal requirement in the location of the Project, any provision in this Bond conflicting with said statutory or legal requirement shall be deemed deleted herefrom and provisions conforming to such statutory or other legal requirement shall be deemed incorporated herein. When furnished, the intent is that this Bond shall be construed as a statutory bond and not as a common law bond.

Signed and sealed this 20th day of December, 2024

(Witness)

(Witness) Edith Forsberg

Truluck Construction, Inc.

(Principal)

(Title)

Merchants Bonding Company (Mutual)

(Surety)

(Title) C. Wayne McCartha, Attorney-in-Fact



Init.

MERCHANTS
BONDING COMPANY™
POWER OF ATTORNEY

Know All Persons By These Presents, that MERCHANTS BONDING COMPANY (MUTUAL) and MERCHANTS NATIONAL BONDING, INC., both being corporations of the State of Iowa, d/b/a Merchants National Indemnity Company (in California only) (herein collectively called the "Companies") do hereby make, constitute and appoint, individually,

C Wayne McCartha; M Kathryn McCartha-Powers; Raymond E Cobb Jr

their true and lawful Attorney(s)-in-Fact, to sign its name as surety(ies) and to execute, seal and acknowledge any and all bonds, undertakings, contracts and other written instruments in the nature thereof, on behalf of the Companies in their business of guaranteeing the fidelity of persons, guaranteeing the performance of contracts and executing or guaranteeing bonds and undertakings required or permitted in any actions or proceedings allowed by law.

This Power-of-Attorney is granted and is signed and sealed by facsimile under and by authority of the following By-Laws adopted by the Board of Directors of Merchants Bonding Company (Mutual) on April 23, 2011 and amended August 14, 2015 and adopted by the Board of Directors of Merchants National Bonding, Inc., on October 16, 2015.

"The President, Secretary, Treasurer, or any Assistant Treasurer or any Assistant Secretary or any Vice President shall have power and authority to appoint Attorneys-in-Fact, and to authorize them to execute on behalf of the Company, and attach the seal of the Company thereto, bonds and undertakings, recognizances, contracts of indemnity and other writings obligatory in the nature thereof."

"The signature of any authorized officer and the seal of the Company may be affixed by facsimile or electronic transmission to any Power of Attorney or Certification thereof authorizing the execution and delivery of any bond, undertaking, recognizance, or other suretyship obligations of the Company, and such signature and seal when so used shall have the same force and effect as though manually fixed."

In connection with obligations in favor of the Florida Department of Transportation only, it is agreed that the power and authority hereby given to the Attorney-in-Fact includes any and all consents for the release of retained percentages and/or final estimates on engineering and construction contracts required by the State of Florida Department of Transportation. It is fully understood that consenting to the State of Florida Department of Transportation making payment of the final estimate to the Contractor and/or its assignee, shall not relieve this surety company of any of its obligations under its bond.

In connection with obligations in favor of the Kentucky Department of Highways only, it is agreed that the power and authority hereby given to the Attorney-in-Fact cannot be modified or revoked unless prior written personal notice of such intent has been given to the Commissioner-Department of Highways of the Commonwealth of Kentucky at least thirty (30) days prior to the modification or revocation.

In Witness Whereof, the Companies have caused this instrument to be signed and sealed this 3rd day of February, 2024.

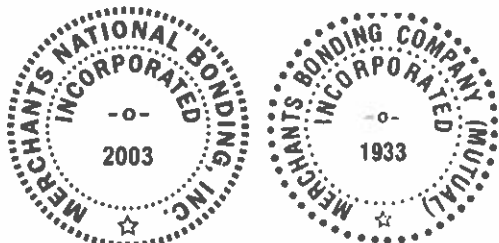

MERCHANTS BONDING COMPANY (MUTUAL)
MERCHANTS NATIONAL BONDING, INC.
d/b/a MERCHANTS NATIONAL INDEMNITY COMPANY

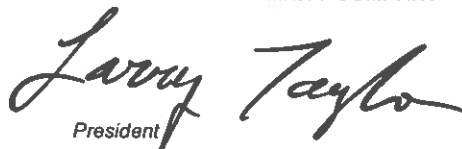
By 
President

STATE OF IOWA
COUNTY OF DALLAS ss.

On this 3rd day of February 2024, before me appeared Larry Taylor, to me personally known, who being by me duly sworn did say that he is President of MERCHANTS BONDING COMPANY (MUTUAL) and MERCHANTS NATIONAL BONDING, INC.; and that the seals affixed to the foregoing instrument are the Corporate Seals of the Companies; and that the said instrument was signed and sealed in behalf of the Companies by authority of their respective Boards of Directors.

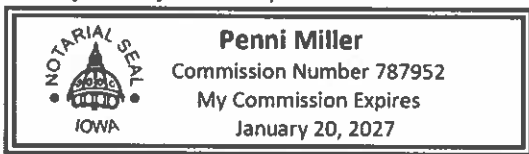

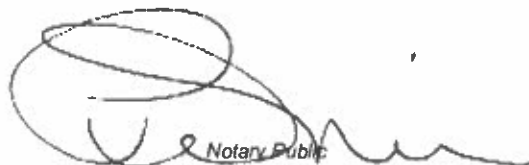

Notary Public

(Expiration of notary's commission does not invalidate this instrument)

I, William Warner, Jr., Secretary of MERCHANTS BONDING COMPANY (MUTUAL) and MERCHANTS NATIONAL BONDING, INC., do hereby certify that the above and foregoing is a true and correct copy of the POWER-OF-ATTORNEY executed by said Companies, which is still in full force and effect and has not been amended or revoked.

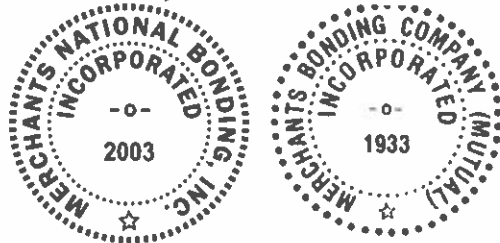
In Witness Whereof, I have hereunto set my hand and affixed the seal of the Companies on this 20th day of December, 2024.



Secretary

Isle of Palms Marina
Public Dock and Intracoastal Dock Improvements
RFB 2023-05
November 21, 2023

1. Bidder's qualifications and certifications: see attached
2. Project Experience and Client Reference:
 - a. Ross Marine
 - i. Owner: Swygert Shipyards, Inc.
 - ii. Owner's Contact: Paul Speights – paulspeights@gmail.com
 - iii. Engineer and Engineer's Contact: HLA – Kyle Neff: kneff@hlainc.com
 - iv. Location: Johns Island, SC
 - v. Contract Date: August 2022
 - vi. Completion Date: February 2023
 - vii. Contract Price: \$4,445,799.00
 - viii. Description: Complete construction, including site work and marine work, of a new marina with dry stacks and floating docks
 - b. West Ashley Greenway Long Creek Bridge Replacement
 - i. Owner: City of Charleston
 - ii. Owner's Contact: Beth Brownlee – brownlee@charleston-sc.gov
 - iii. Engineer and Engineer's Contact: JGT – Chris Moore: cmoore@jgtinc.com
 - iv. Location: West Ashley Greenway, Charleston, SC
 - v. Contract Date: June 2022
 - vi. Completion Date: November 2022
 - vii. Contract Price: \$396,304.00
 - viii. Description: Replacement of the bridge spanning Long Creek on the West Ashley Greenway. Work included support of adjacent CWS sanitary sewer pipe, erosion controls, gabion walls, concrete foundation, asphalt paving, and other related improvements
 - c. Gun Bluff Road Bridge Repairs
 - i. Owner: Charleston County
 - ii. Owner's Contact: Buck Dukes – hdukes@charlestoncounty.org
 - iii. Location: Edisto Island, SC
 - iv. Contract Date: June 2023
 - v. Completion Date: July 2023
 - vi. Contract Price: \$69,843.00
 - vii. Description: Demolition and replacement of existing defective bridge
 - d. Dolphin Cove Marina Replacement
 - i. Owner: Dolphin Cove Marina
 - ii. Owner's Contact: Debbie Brown – 404-808-4478
 - iii. Location: Charleston, SC
 - iv. Completion Date: April 2023
 - v. Contract Price: \$682,000.00
 - vi. Description: Demo damaged dock, installed 48ea 65' timber piles and 9,248 SF of new dock and waterlines in under one month

3. Subcontractor Information:
 - a. Additional Marine Work Support: R. L. Morrison & Sons, Inc. – Michael Morrison: 843-887-3261
 - b. Plumbing/Utilities Work: B+C Utilities – Charles Rooke: 843-200-8740
 - c. Electric Work: Gibson Electric – Alan Gibson: 803-513-1249
 - d. Dock Supplier: Meeco Sullivan
 - e. Gangway Supplier: Meeco Sullivan/Ravens Marine
 - f. Supporting Engineer: Meeco Sullivan Supplied/JGT
4. Proposed work plan and schedule: See attached
5. Bid Form: See attached
6. Bid Bond: See attached
7. Subcontractors
 - a. Maner Fencing – Fence and gate controls
 - b. Gibson Electric – electric work
 - c. Pleasant Places – Landscaping
 - d. Soil Consultants – concrete Testing
8. Addendum: Questions and answers posted 12/16/24 RECEIVED

**CITY OF ISLE OF PALMS, SOUTH CAROLINA
REQUEST FOR BID (RFB) 2024-12
COUNTY PARK EMERGENCY ACCESS**

The City of Isle of Palms is seeking bids from qualified general contractors for the construction of a public safety path through the Charleston County Park that will include demolition, grading, new sidewalks, driveways, power supply, gates, fencing, landscaping, and other improvements. This request is being made and awarded pursuant to the City's procurement ordinance. The City reserves the right to reject any and all bids and to waive irregularities.

Bids should be submitted to the following:

Douglas Kerr
Deputy City Administrator
City of Isle of Palms
1207 Palm Boulevard
Post Office Box 508
Isle of Palms, South Carolina 29451

Deadline for Questions

The deadline for questions is 5:00 p.m., Eastern Time, Friday, December 13th, 2024. Bidders should send questions regarding this Request for Bids to Douglas Kerr, Deputy Administrator, in writing or email to dkerr@iop.net. Questions received before this deadline will be answered via addendum posted on the City's website at <http://www.iop.net/requests-for-bids-proposals>. Questions received after this deadline will not be answered.

If an addendum is issued, Bidders must acknowledge receipt of the addendum with their bid.

Deadline for Submissions

The deadline for submission is 10:00 a.m., Eastern Time, Friday, December 20th, 2024. Bids will be received at 1207 Palm Boulevard, Isle of Palms, South Carolina 29451 in a sealed envelope. Sealed envelopes must be clearly marked "RFB 2024-12, County Park Emergency Path" and include one (1) hard copy and one (1) electronic copy saved to a USB flash drive. It will be the responsibility of the bidders to verify receipt by the City.

Bids may be delivered by hand or by mail, but no bid shall be considered which is not actually received by the City at the place, date and time appointed by the City and the City shall not be responsible for any failure, misdirection, delay or error resulting from the selection by any bidder of any particular means of delivery.

Proprietary and/or Confidential Information: Your bid is a public document under the South Carolina Freedom of Information Act (FOIA), except as to information that may be treated as confidential as an exception to disclosure under the FOIA. If you cannot agree to this standard, please do not submit your bid. All information that is to be treated as confidential and/or proprietary must be CLEARLY identified, and each page containing confidential and/or proprietary information, in whole or in part, must be stamped and/or denoted as CONFIDENTIAL, in bold, in a font of at least 12-point type, in the upper right-hand corner of the page. All information not so denoted and identified will be subject to disclosure by the City.

Bidders acknowledge and agree that the City will not be liable for any costs, expenses, losses, damages (including damages for loss of anticipated profit) or liabilities incurred by the respondent or any member of the respondent's organization as a result of, or arising out of, submitting a bid, negotiating changes, or due to the City's acceptance or non-acceptance of the bid or the rejection of any and all bids. Bidders are responsible for submission of accurate, adequate and clear descriptions of the information requests. Neither issuance of the RFB, preparation and submission of a response, nor the subsequent receipt and evaluation of any response by the City of Isle of Palms will commit the City to award a contract to any respondent even if all the requirements in the RFB have been met.

Bidders must have or be able to procure an Isle of Palms Business License.

Contractors considering submission under this RFB will be expected to have read and be prepared to enter into the attached contract, which is a part of this RFB. The City of Isle of Palms reserves the right to accept or reject any and all bids, or any parts thereof; to waive irregularities or informalities in any bid received to allow the bid to be considered; to negotiate terms and conditions with Bidders; and to select a Bidder or to cancel in whole or in part this RFB, if it is in the best interest of the City to do so. Those bids determined not to be in compliance with provisions of this RFB and the applicable laws and or regulations will not be processed.

By signing its bid, Bidder certifies that it will comply with the applicable requirements of Title 8, Chapter 14 of the South Carolina Code of Laws and agrees to provide the City upon request any documentation required to establish either: (a) that Title 8, Chapter 14 is inapplicable both to Bidder and its subcontractors or sub-subcontractors; or (b) that Bidder and its subcontractors or sub-subcontractors are in compliance with Title 8, Chapter 14. Pursuant to Section 8-14-60, "A person who knowingly makes or files any

false, fictitious, or fraudulent document, statement, or report pursuant to this chapter is guilty of a felony and, upon conviction, must be fined within the discretion of the court or imprisoned for not more than five years, or both.” Bidder agrees to include in any contracts with its subcontractors language requiring its subcontractors to (a) comply with the applicable requirements of Title 8, Chapter 14 and (b) include in their contracts with subcontractors, language requiring the sub-subcontractors to comply with the applicable requirements of Title 8, Chapter 14.

Scope of Work

A site visit to the Isle of Palms County Park is recommended prior to submitting a bid.

The Scope of work for the project includes, but is not limited to the following:

1. Sawcut and remove portions of existing sidewalks
2. Removal of certain vegetation
3. Installation of underground electrical and irrigation conduit as shown on the plans
4. Regrading and creation of berms around the vehicle pull off area
5. Installation of new concrete sidewalk- 7 feet wide at some points and 14 feet wide at some points
6. Installation of new driving surface created with 6-inch-thick concrete in the right-of-way, dual Turfstone paver strips in the driving sections of the pathway and full Turfstone paver area in the pull off and turning area, with all Turfstone supported on the edges by curbing depressed 1.5 inches below the top of the Turfstone
7. New swing gates at the beach and roadway end of the path to match the existing fencing in material, color, design, and material thicknesses
8. New slide gate at the road end of the path to match the existing fencing in material, color, design, and material thicknesses
9. The slide gate is to be remote operated by the City Public Safety staff and the County Park staff
10. New clatter bridge to be constructed with 6"x8" timbers with three strands of ½" stainless steel wire and PVC washers and terminal bolts, measuring 150' long x10' wide
11. Construct new 24"x24" grate inlet over an existing RCP adjacent to Ocean Boulevard
12. Landscaping as shown on the attached plans
13. Any other work shown on the plans from Davis and Floyd dated September 2024

The chosen contractor shall provide all materials, equipment, supplies, freight, state sales tax, labor and supervision as necessary.

A performance bond for 100% of the construction contract amount will be required.

Time is of the essence for this project and all work associated with this RFB must be completed within 90 days of the issuance of the Notice to Proceed.

Bid Format

In responding to this request, contractors should provide a price quote for the scope of work to accomplish this work on the attached "BID FORM". Contractors should also provide a cost breakdown of the scope of work on the "ITEMIZED COST" form. Certain portions of the project may be excluded, because of budget constraints and the itemized cost portion of the bid form will be used to determine how to

If any addenda(um) are issued, the contractor must acknowledge reviewing the addenda(um) by listing them on the BID FORM.

In addition to submitting the completed BID FORM, contractors submitting bids should provide examples of experience with similar projects. Provide a brief description of similar projects of comparable size and complexity for which the Bidder provided services within the past five (5) years. Limit information to no more than five projects.

All such descriptions should include:

1. Project location.
2. Renovation and/or Replacement.
3. Description of original project budget versus actual cost.
4. Name and contact information for a reference with knowledge of the Bidder's work on the specified project.

Provide the Contractor(s) and if possible the names and bids of all sub-consultants that will be part of the Bidder's Team and identify the specific work the sub-consultant will perform. Once the City issues a contract, no change in sub-consultants assigned to the project will be permitted without prior written approval from the City.

Evaluation Criteria

The City will evaluate bids based on the factors outlined within this RFB and the City's procurement ordinance, which shall be applied to all eligible, responsive bids in selecting the successful contractor. The City reserves the right to disqualify any bid from a bidder it deems as non-responsive and/or non-responsible. The City reserves the right to make such investigations of the Bidders as it deems appropriate.

Award of any contract may be made without discussion with Bidders after bids are received. The City reserves the right to cease contract negotiations if it is determined that the Bidder cannot perform the services specified in their response.

Recommendation of award for contract will be made based not only on price, which is an important factor, but also on quality of bid, qualifications, experience, technical

expertise, references and ability to execute the work.

BID FORM

BID OF: _____

(Contractor)

BID TO: The City of Isle of Palms

(Owner)

PROJECT NAME: County Park Emergency Access

PROJECT NUMBER: RFB 2024-12

BID DATE: _____

BASE BID AGREEMENT

The undersigned, having examined all the Bidding Documents, including all Addendum(a) as follows:

Plans from Davis and Floyd dated September 2024

shall execute the entire Work in the Bidding Documents described as the Base Bid for the lump sum of:

_____ Dollars

BID AMOUNT (all work) \$ _____

ITEMIZED COSTS (each item should be included in the BASE BID amount)

1. All demolition, site preparation grading and compacting.
_____ Cost
2. Installation of electrical and irrigation conduit.
_____ Cost
3. Total Turfstone installation including base, preparation, and edging.
_____ Cost
4. Total concrete installation including base and preparation.
_____ Cost
5. All fencing and gate installation.
_____ Cost
6. All cladder bridge installation.
_____ Cost
7. All drainage work outside of grading (which is included in 1. above).
_____ Cost
8. Total concrete installation including base and preparation.
_____ Cost
9. All fencing and gate installation.
_____ Cost
10. All cladder bridge installation.
_____ Cost
11. All drainage work outside of grading (which is included in 1. above).
_____ Cost
12. All cladder bridge installation.
_____ Cost
13. All landscaping installation.
_____ Cost
14. Miscellaneous Total concrete installation including base and preparation.
_____ Cost
15. All fencing and gate installation.
_____ Cost
16. All clatter bridge installation (150'x10').
_____ Cost
17. All other miscellaneous work.
_____ Cost

TOTAL BASE BID (sum of all lines above) _____

DATE FOR COMMENCEMENT AND SUBSTANTIAL COMPLETION

The Date for Commencement shall be established in the Notice to Proceed. The Contractor shall not incur any expense until the contract has been awarded. An award requires that either the Contract be signed by both the awarding authority and the contractor or a Notice to Proceed is executed.

All work for additions shall be substantially completed (as evidenced by the date on the CERTIFICATE OF SUBSTANTIAL COMPLETION) within: NINETY (90) calendar days from the date set forth in the NOTICE TO PROCEED, subject to adjustments as provided in the Contract Documents.

Final completion of all work shall be performed within: THIRTY (30) calendar days from the scheduled contract time for substantial completion, subject to adjustments as provided in the Contract Documents.

The undersigned further agrees that from the compensation to be paid, the owner may retain as liquidated damages the sum of one thousand dollars (\$1,000) for each calendar day the actual contract time for Substantial Completion for the project exceeds the specified or adjusted contract time for Substantial Completion as provided in the Contract Documents.

THIS AGREEMENT IS SUBJECT TO BINDING ARBITRATION PURSUANT TO SOUTH CAROLINA CODE SECTION 15-48-10, ET SEQ., AS AMENDED

STATE OF SOUTH CAROLINA) County Park
) Emergency Access
COUNTY OF CHARLESTON)

THIS AGREEMENT (“Agreement”) is made and entered into this ____ day of _____, 2024, by and between the City of Isle of Palms, S.C., a South Carolina municipal corporation (“City”), and _____ (“Contractor”).

WHEREAS, Contractor was the successful bidder under the City’s solicitation for bids for the County Park Emergency Access; and

WHEREAS, the parties hereto desire to enter into this Agreement to set forth the exact rights, duties and obligations of each party regarding the services to be performed by Contractor pursuant to the bid.

THEREFORE, in consideration of the mutual covenants and promises set forth herein,

City and Contractor agree as follows:

1. SCOPE OF WORK.

A. Contractor agrees to provide all labor, equipment, tools, materials, supplies, and incidentals necessary for County Park Emergency Access project, pursuant to the bid submitted by Contractor to City dated _____ (the “Bid”), a copy of which is attached hereto as “Exhibit I” and made a part of this Agreement by reference thereto. In the event of any conflict between the provisions of this Agreement and the Solicitation, the term of this Agreement shall control.

B. Contractor agrees to use its best skill and attention and be solely responsible for all means, methods, techniques, sequences, and procedures in the performance of the work on the Project. Contractor hereby warrants to City that all work on the Project shall be performed in a good and workmanlike manner. Contractor agrees to comply with all applicable federal, state and local laws, rules and regulations regarding all work performed by Contractor pursuant to this Agreement.

2. CONTRACT PRICE. For all work under this Agreement, City agrees to pay to

Contractor the sum of _____ (\$ _____) Dollars, payable upon completion of the Project.

3. CHANGE ORDERS. The City has the right to require alterations or changes ("Change Orders") to the Project and in such case Contractor agrees to make such alterations or changes; provided, however, that the details and additional cost or credit of such Change Order must be agreed to by the City and Contractor in writing prior to the commencement of the Change Order.

4. COMPLETION SCHEDULE. TIME IS OF THE ESSENCE. Contractor agrees to complete the Project within ninety (90) days from the date of this Agreement. Provided, however, that if performance by the Contractor is delayed for reasons or causes beyond the control of Contractor (including but not limited to, acts of God, weather conditions, site conditions, labor or material shortages, delays caused by City, and casualty losses) the Project completion date shall be extended accordingly.

5. INSURANCE. Contractor agrees to maintain comprehensive general liability insurance coverage on the work under the Project in an amount not less than \$1,000,000.00 per person, \$2,000,000.00 per claim, and \$250,000.00 per claim for property damage. Contractor also agrees to maintain worker's compensation coverage on its employees as required by the State of South Carolina workers' compensation laws. All insurance coverage required hereunder shall be with companies approved in advance by City, who shall be named as an additional insured on all such policies. Proof of such insurance shall be provided to City prior to commencement of any work by Contractor.

6. PERMITS, FEES AND LICENSES. Contractor agrees to apply for, obtain and pay for all permits, fees, licenses and inspections by governmental agencies necessary for the Contractor's proper performance and completion of the Project, including, but not limited to, a City business license.

7. INDEMNIFICATION. Contractor agrees to hold harmless and indemnify City and the County its officers, agents and employees from and against any loss or damage, including all reasonable attorney's fees and expenses, incurred as a result of any and all claims, demands, causes of action, suits, judgments, fines or penalties (including but not limited to all fees and expenses incurred as a result of death or injury to persons or for loss of or damage to property) arising out of or in connection with Contractor's performance of the work under this Agreement.

8. SITE INVESTIGATION. Contractor acknowledges that Contractor has had the opportunity to inspect the service areas, has determined the nature of the work and the difficulties and facilities attending performance of the work, and all other matters which Contractor contemplates may in any way affect the work under this Agreement.

9. **BINDING ARBITRATION.** Any dispute or controversy arising under or in connection with this Agreement shall be submitted to binding arbitration in accordance with the requirements of the South Carolina Uniform Arbitration Act as then in effect (“SCUAA”). All arbitration proceedings shall be conducted in Charleston County, South Carolina. The arbitrators shall be selected as provided in the SCUAA, and the arbitrators shall render a decision on any dispute within ninety (90) days after the last of the arbitrators has been selected. If any party to this Agreement fails to select an arbitrator with regard to any dispute submitted to Arbitration under this Section within thirty (30) days after receiving notice of the submission to arbitration of such dispute, then the other party or parties shall select an arbitrator for such nonselecting party, and the decision of the arbitrators shall be final and binding upon all the parties to the dispute, their personal representatives, legal representatives, heirs, successors and assigns. The prevailing party in any such proceeding shall be entitled to reimbursement by the losing party, in addition to any damages awarded, for all reasonable costs and expenses, including attorney’s fees, incurred in any such proceeding, including all trial and appellate levels. Nothing contained in this Section shall preclude either party from seeking injunctive relief through a court of competent jurisdiction in connection with the Arbitration, and the prevailing party shall also be entitled to reimbursement by the losing party for all reasonable fees and costs, including attorney’s fees, incurred in the proceedings seeking injunctive relief.

10. **BREACH.**

A. In the event that either party breaches any provision of this Agreement, and the same continues for a period of seven (7) days after receipt of written notice thereof, then the nonbreaching party may exercise any and all remedies at law or in equity regarding the breach of this Agreement. Without prejudice to any other rights or remedies available for the said breach, the non-breaching party may terminate this Agreement and cease further performance under this Agreement.

B. Unless authorized by this Agreement, if the Contractor completely ceases work on the Project for a period of fifteen (15) days, or defaults or persistently fails or neglects to carry out the Project, the City may, after seven (7) days’ written notice to the Contractor, complete the Project and if the unpaid balance of the contract price exceeds the City’s actual cost of completing the Project, such excess shall be paid to the Contractor, but if such expense exceeds the unpaid balance, the Contractor shall pay the difference to the City.

11. **EFFECT OF WAIVER OR CONSENT.** A waiver or consent, express or implied, to or of any breach or default by a party in the performance of its obligations under this Agreement is not a consent or waiver to or of any other breach or default in the performance by that party of the same or any other obligations of that party with respect

to this Agreement. Failure on the part of a party to complain of any act of the other party or to declare a party in default with respect to this Agreement, irrespective of how long that failure continues, does not constitute a waiver by that party of its rights with respect to that default until the applicable statute-of-limitation period has run.

12. SUB-CONTRACT OR ASSIGNMENT. Contractor agrees not to enter into any subcontracts or assignments pertaining to the performance of all or any part of this Agreement, either voluntarily or by operation of law, without prior written approval of City.

13. BINDING AGREEMENT. This Agreement shall be binding upon and inure to the benefit of the parties hereto and their respective successors and permitted assigns.

14. GOVERNING LAW; SEVERABILITY. This Agreement is governed by and shall be construed and interpreted in accordance with the laws of the State of South Carolina. If any provision of this Agreement is held invalid or unenforceable to any extent by a court of competent jurisdiction, the remainder of this Agreement is not affected thereby and that provision shall be enforced to the greatest extent permitted by law.

15. ENTIRE AGREEMENT. This Agreement constitutes the entire agreement between the parties hereto relating to the subject matter hereof, and supersedes and nullifies all prior or contemporaneous contracts, agreements, understandings or representations, whether oral or written, which are not expressly stated in this agreement. Neither party is relying upon any representation not expressly contained herein. This Agreement may be amended and modified from time to time only upon the written mutual consent of City and Contractor.

16. SECTION HEADINGS. The headings of Sections or paragraphs used in this Agreement have been inserted for convenience only and are not to be used in determining the contents contained herein.

IN WITNESS WHEREOF, the City and Contractor have hereunto set their hands and seals, by and through the undersigned officers, as of the day and year first above written.

WITNESS:

Contractor:

(#1 as to Contractor)

By: _____

(#2 as to Contractor)

Title: _____

The City of Isle of Palms, S.C.:

(#1 as to City)

By: _____

(#2 as to City)

Title: _____

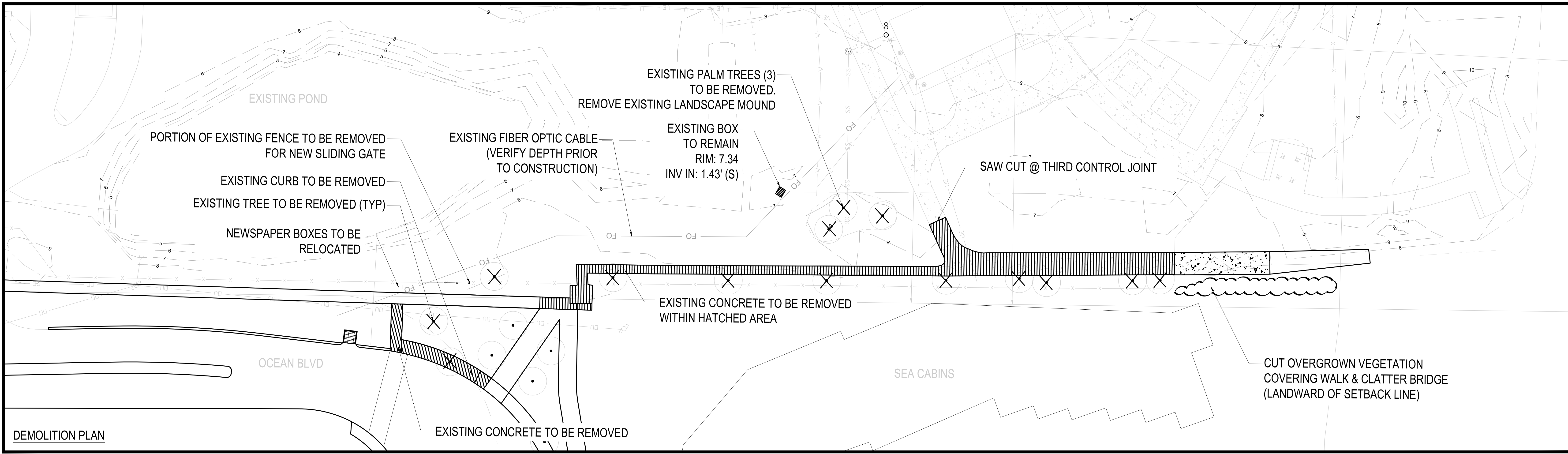

DEMOLITION PLAN

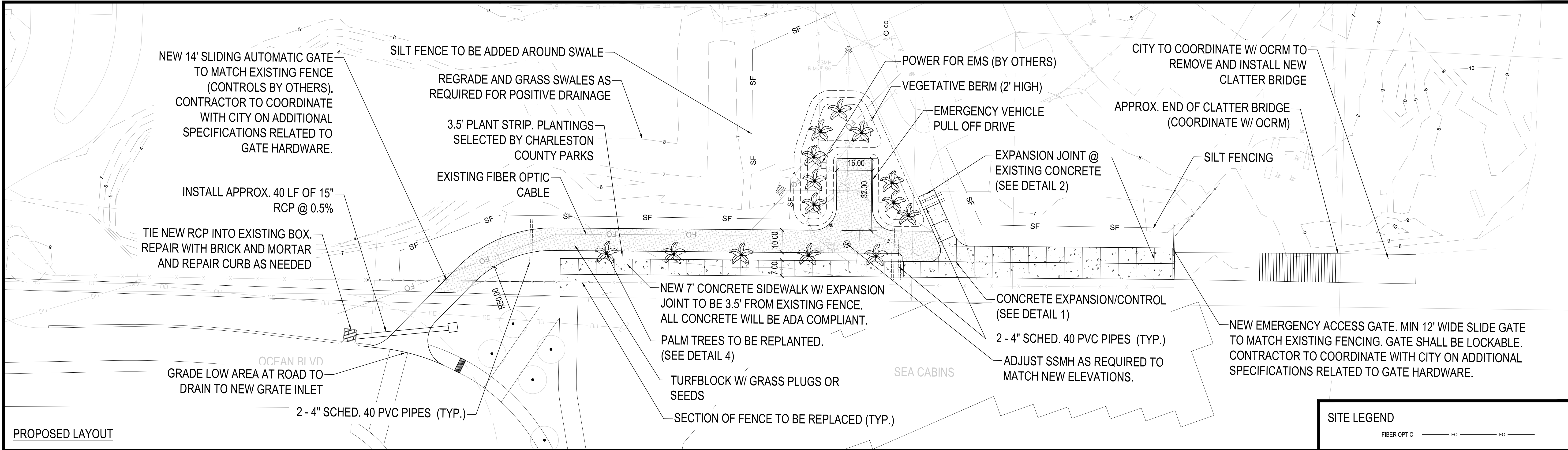

PROPOSED LAYOUT

SITE LEGEND

FIBER OPTIC — FO — FO —

4" THICK CONCRETE PAVING, REINFORCE AS PER PLANS OR SPECIFICATIONS.

3/4" DEEP TOOLED JOINT.

TYPICAL 4" THICK SAND BED OVER COMPACTED SUB-GRADE.

CONTROL JOINT

1/2" DIA. X 24" SMOOTH STEEL DOWEL W/ SLEEVE AT ONE END, 48" O.C. TWO MIN. PER JOINT.

EXPANSION JOINT: 1/2" FELT WITH BREAK AWAY TAB, CAULK WITH GREY SEALANT.

TYPICAL 4" THICK SAND BED OVER COMPACTED SUB-GRADE.

EXPANSION JOINT

EXISTING CONCRETE PAVING.

EXPANSION JOINT: 1/2" FELT WITH BREAK AWAY TAB, CAULK WITH GREY SEALANT.

NEW CONCRETE PAVING.

DRILL A 1-1/2" DIA. X 3" HOLE IN THE EXISTING CONCRETE AND IMBED THE SLEEVE WITH HIGH STRENGTH GROUT.

1/2" DIA. X 18" SMOOTH STEEL DOWEL W/ SLEEVE AT 48" O.C., TWO MINIMUM PER JOINT.

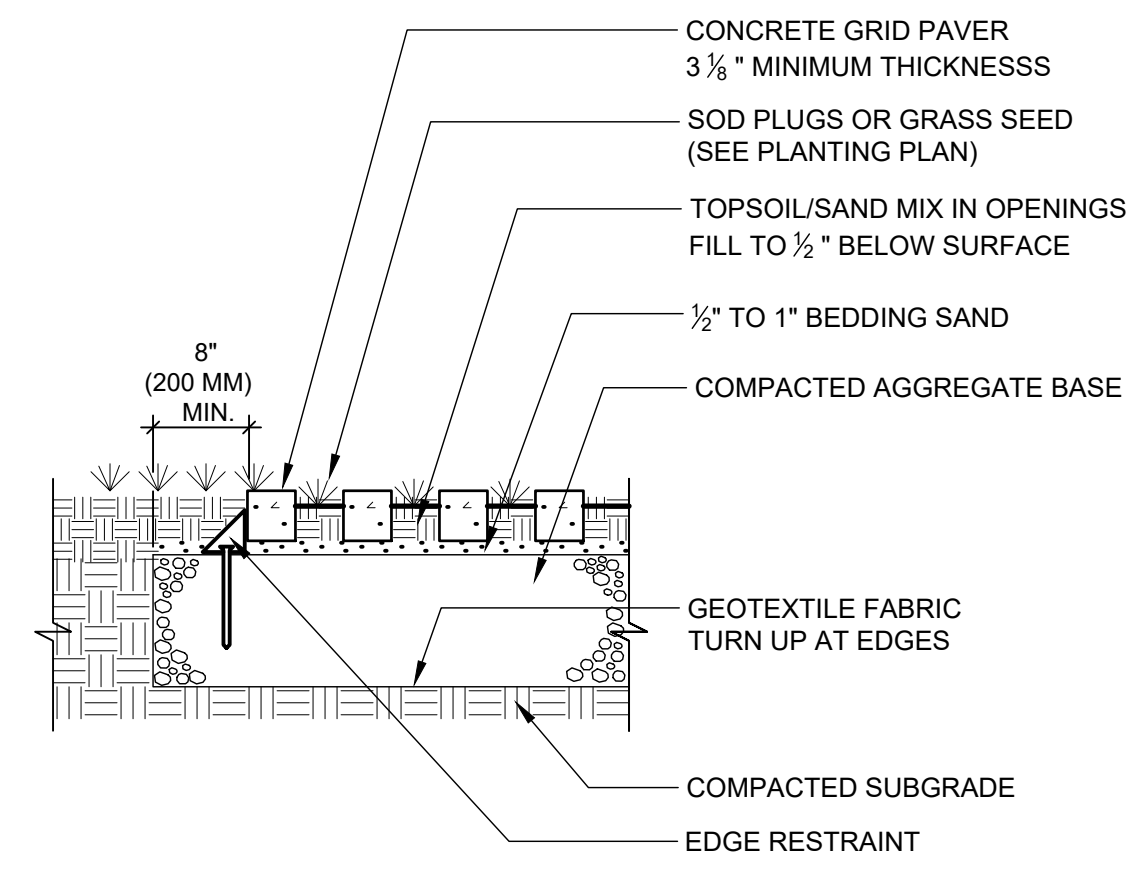

- NOTES:
1. BASE THICKNESS VARIES WITH TRAFFIC, CLIMATE AND SUBGRADE.
 2. MINIMUM BASE THICKNESS: 6" (150 MM) RESIDENTIAL DRIVEWAYS, 8" (200 MM) FIRELANES & PARKING LOTS.

- NOTES:
1. SABAL PALMETTOS SHALL BE DEFOLIATED.
 2. CABBAGE HEAD TO BE PROTECTED FROM DAMAGE.
 3. ALL TREES MUST ORIGINATE FROM NORTH FLORIDA.
 4. ALL PALMETTOS SHALL BE SPRAY TREATED WITH AN APPROVED INSECTICIDE AT TIME OF ORIGINAL TRANSPLANTING AND AGAIN AT TIME OF PLANTING.
 5. TRUNKS OF PALMETTOS SHALL BE NEARLY UNIFORM IN SIZE OVER ENTIRE HEIGHT AND SHALL BE FREE OF OLD FROND STUBS, FIRE BLACK, AND OTHER DAMAGE.

- REMOVE PALM FRONDS FROM TREE PRIOR TO TRANSPORTING
- MAINTAIN TREE IN A PLUMB UPRIGHT POSITION. FOR WINDY AREAS USE SLIGHTLY TALLER TREES AND BURY ROOT BALL DEEPER FOR EXTRA STABILITY.
- 3" THICK MULCH
- ROUND-TOPPED SOIL BERM 6" HIGH X 12" WIDE ABOVE ROOT BALL SURFACE SHALL BE CONSTRUCTED AROUND THE ROOT BALL. BERM SHALL BEGIN AT ROOT BALL PERIPHERY.
- FINISHED GRADE
- PLANTING MIXTURE
- UNDISTURBED SUBGRADE

4 TYPICAL PALM TREE PLANTING

NTS

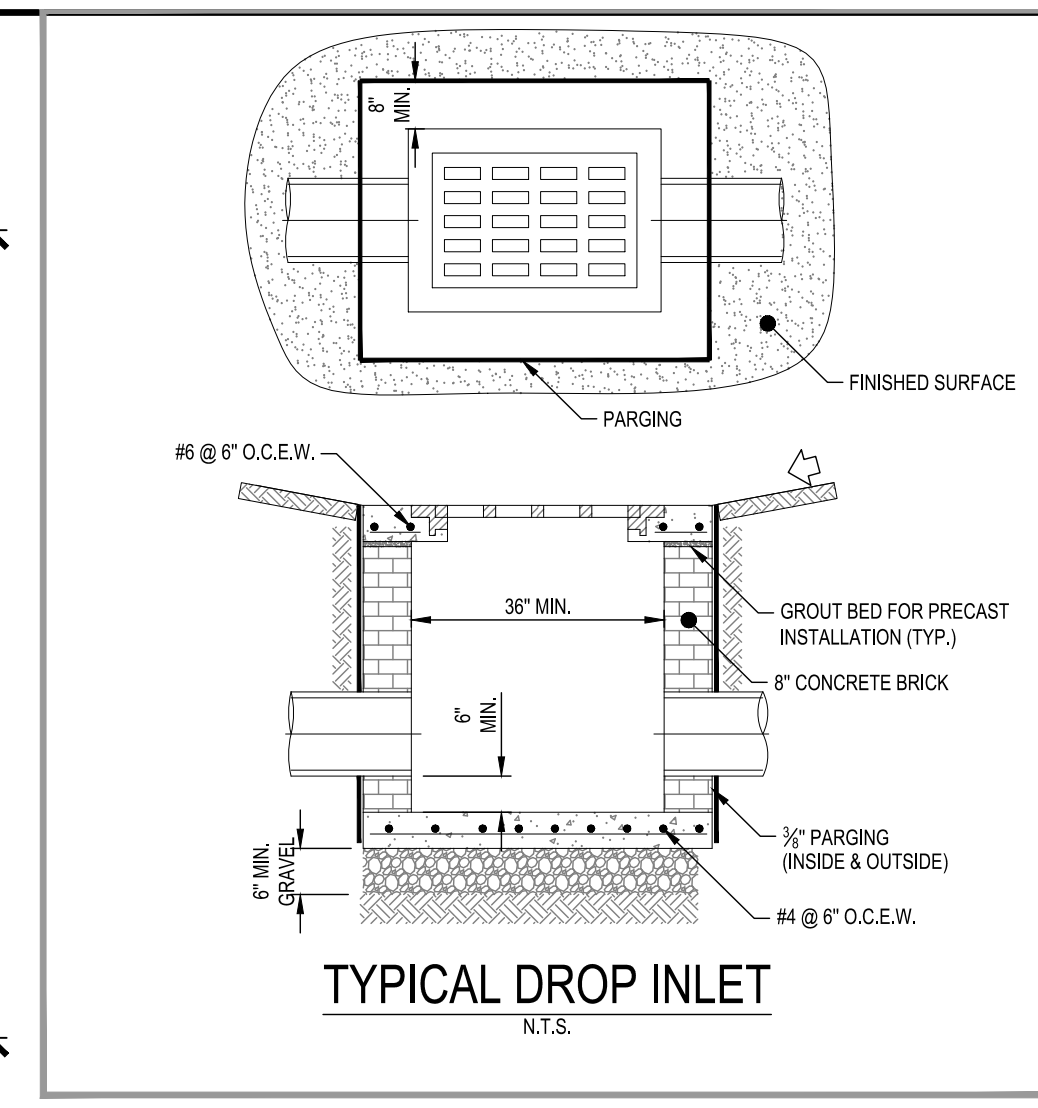

TYPICAL DROP INLET

NTS

1 CONCRETE EXPANSION/CONTROL

1 1/2" = 1'-0"

P-CO-IOP1-02

2 CONCRETE JOINT AT EXISTING PAVING

3" = 1'-0"

P-CO-IOP1-01

3 TURFSTONE PERMEABLE PAVER

NTS
1" = 1'-0"

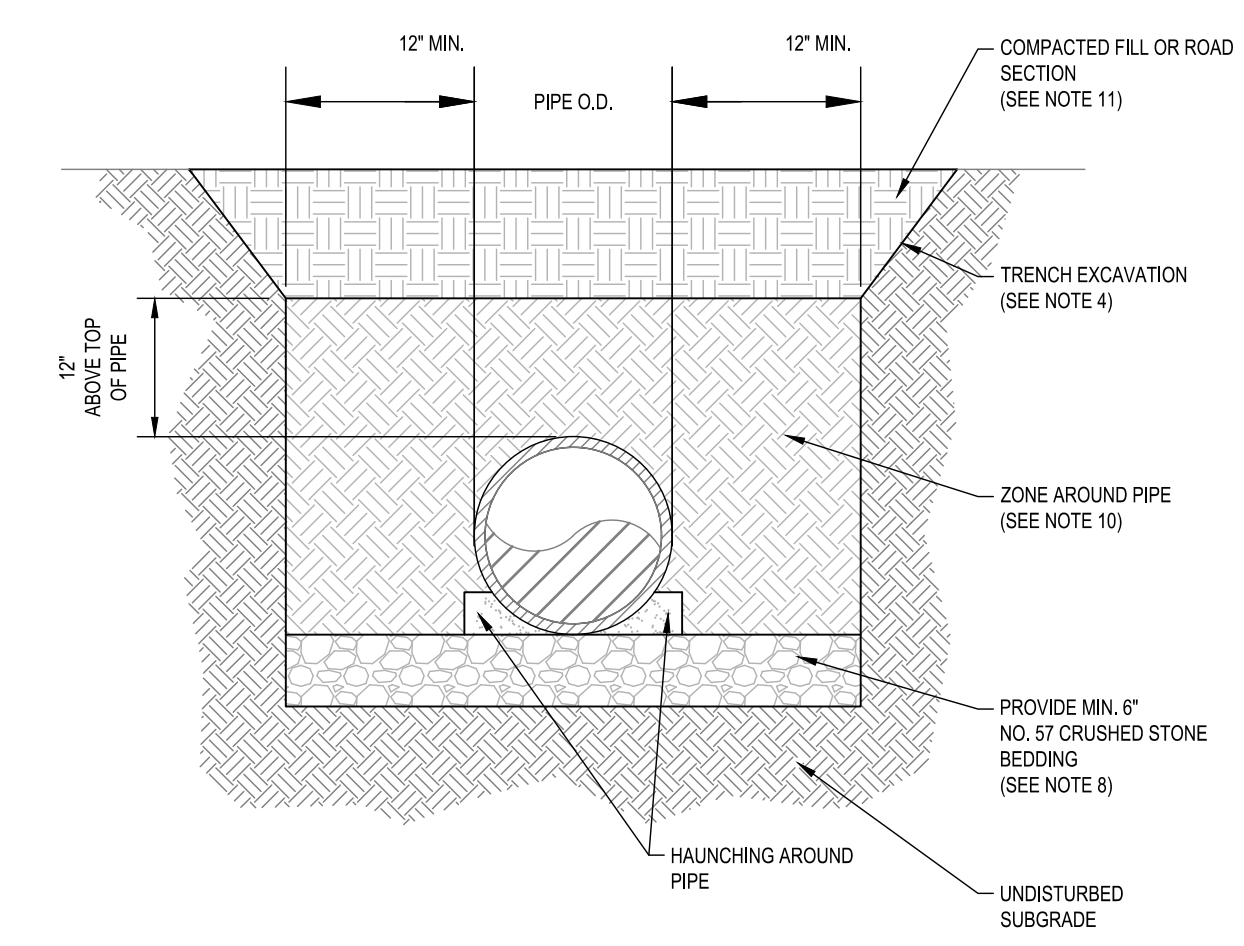

- NOTES:
1. ALL MATERIALS AND CONSTRUCTION SHALL CONFORM TO SCDOT STANDARD SPECIFICATIONS FOR HIGHWAY CONSTRUCTION, LATEST EDITION, UNLESS NOTED OTHERWISE.
 2. ALL INSTALLATIONS SHALL BE PERFORMED IN ACCORDANCE WITH PIPE MANUFACTURER'S RECOMMENDATION.
 3. PROTECT EXISTING STRUCTURES, UTILITIES, SIDEWALKS, PAVEMENTS, AND OTHER FACILITIES FROM DAMAGES CAUSED BY SETTLEMENT, LATERAL MOVEMENT, UNDERMINING, WASHOUT, AND OTHER HAZARDS CREATED BY TRENCHING OPERATIONS.
 4. SLOPE, BRUSH, BRACE SHORE, OR SHIELD ALL TRENCH EXCAVATIONS IN ACCORDANCE WITH OSHA CONSTRUCTION STANDARDS FOR EXCAVATION.
 5. PROVIDE PUMPING AND DRAINAGE FACILITIES ADEQUATE TO KEEP THE EXCAVATED AREA SUFFICIENTLY DRY FROM GROUNDWATER AND SURFACE RUNOFF DURING CONSTRUCTION.
 6. FINE GRADE THE BOTTOM OF TRENCH TO ALLOW FIRM BEARING OF THE BOTTOM OF THE PIPE. PROVIDE BELL HOLES AT EACH JOINT LOCATION.
 7. WRAP ALL PIPE JOINTS WITH MIN. 6 OZ/SY NON-WOVEN FILTER FABRIC, US 160NW OR EQUIVALENT.
 8. PROVIDE CRUSHED STONE OR GRAVEL BEDDING MEETING ASTM C 33, GRADATION 57 (NO. 57), UNDERCUT UNSUITABLE SOILS IN TRENCH BOTTOMS AND PROVIDE ADDITIONAL UNITS OF STONE BEDDING AS DIRECTED BY THE ENGINEER.
 9. BACKFILL TRENCH WITH SUITABLE NATIVE MATERIALS WITH NO FRAGMENTS LARGER THAN 2 INCHES IN GREATEST DIMENSION. BACKFILL UP TO A LEVEL OF 2 FEET OVER TOP OF THE PIPE SHALL CONTAIN NO ROCK, CLOS, OR ORGANIC MATERIALS.
 10. BACKFILL IN ZONE AROUND PIPE TO BE PLACED IN 6" LIFTS AND COMPACTED TO 100% STANDARD PROCTOR MAX. DENSITY (TEST METHOD C, ASTM D698), OR AS DIRECTED BY GEOTECHNICAL ENGINEER. COMPACT THOROUGHLY UNDER PIPE HAUNCHES AND TAMP UNIFORMLY TO PREVENT LATERAL DISPLACEMENT OF THE PIPE.
 11. REMAINING BACKFILL ABOVE PIPE ZONE SHALL BE COMPACTED TO 92% MAX. DENSITY IN UNPAVED AREAS, OR 95% MAX. DENSITY IN PAVED AREAS, UNLESS NOTED OTHERWISE.

RCP TRENCH

NTS

ISLE OF PALMS EMERGENCY ACCESS DETAILS

ISLE OF PALMS, SOUTH CAROLINA
SEPTEMBER 2023
32041.00

NOTE: THIS EXHIBIT IS FOR CONCEPTUAL PURPOSES ONLY. NO SURVEY WAS CONDUCTED TO ESTABLISH EXISTING CONDITIONS. THESE DRAWINGS AND THE DESIGN THEREON ARE THE PROPERTY OF DAVIS & FLOYD, INC. AND MAY NOT BE USED IN WHOLE OR IN PART WITHOUT WRITTEN CONSENT OF THE ENGINEER / ARCHITECT AND ANY INFRINGEMENT WILL BE SUBJECT TO LEGAL ACTION.
G:\Jobs\001\32041-00\Production\LandscapeArch_Planning\DWG\32041.00-SITE.dwg, 11/10/2023 1:07:14 PM, Danielle Valdés

- GENERAL NOTES:**
- DO NOT PLACE SILT FENCE ACROSS CHANNELS OR IN OTHER AREAS SUBJECT TO CONCENTRATED FLOWS. SILT FENCE SHOULD NOT BE USED AS A VELOCITY CONTROL BMP. CONCENTRATED FLOWS ARE ANY FLOWS GREATER THAN 0.5 CFS.
 - MAXIMUM SHEET OR OVERLAND FLOW PATH LENGTH TO THE SILT FENCE SHALL BE 100-FEET.
 - MAXIMUM SLOPE STEEPNESS (NORMAL [PERPENDICULAR] TO THE FENCE LINE) SHALL BE 2:1.
 - SILT FENCE JOINTS, WHEN NECESSARY, SHALL BE COMPLETED BY ONE OF THE FOLLOWING OPTIONS:
 - WRAP EACH FABRIC TOGETHER AT A SUPPORT POST WITH BOTH ENDS FASTENED TO THE POST, WITH A 1-FOOT MINIMUM OVERLAP.
 - OVERLAP SILT FENCE BY INSTALLING 3-FEET PASSED THE SUPPORT POST TO WHICH THE NEW SILT FENCE ROLL IS ATTACHED. ATTACH OLD ROLL TO NEW ROLL WITH HEAVY DUTY PLASTIC TIES OR
 - OVERLAP ENTIRE WIDTH OF EACH SILT FENCE ROLL FROM ONE SUPPORT POST TO THE NEXT SUPPORT POST.
 - ATTACH FILTER FABRIC TO THE STEEL POSTS USING HEAVY-DUTY PLASTIC TIES THAT ARE EVENLY SPACED WITHIN THE TOP 8-INCHES OF THE FABRIC.
 - INSTALL THE SILT FENCE PERPENDICULAR TO THE DIRECTION OF THE STORM WATER FLOW AND PLACE THE SILT FENCE THE PROPER DISTANCE FROM THE TOE OF STEEP SLOPES TO PROVIDE SEDIMENT STORAGE AND ACCESS FOR MAINTENANCE AND CLEAN OUT.
 - INSTALL SILT FENCE CHECKS (TIE-BACKS) EVERY 50-100 FEET, DEPENDENT ON SLOPE, ALONG SILT FENCE THAT IS INSTALLED WITH SLOPE AND WHERE CONCENTRATED FLOWS ARE EXPECTED OR ARE DOCUMENTED ALONG THE PROPOSED/INSTALLED SILT FENCE.

- POST REQUIREMENTS:**
- SILT FENCE POSTS MUST BE 48-INCH LONG STEEL POSTS THAT MEET, AT A MINIMUM, THE FOLLOWING PHYSICAL CHARACTERISTICS:
 - COMPOSED OF A HIGH STRENGTH STEEL WITH A MINIMUM YIELD STRENGTH OF 50,000 PSI
 - INCLUDE A STANDARD "T" SECTION WITH A NOMINAL FACE WIDTH OF 1.38-INCHES AND A NOMINAL "T" LENGTH OF 1.48-INCHES.
 - WEIGH 1.25 POUNDS PER FOOT (± 8%)
 - POSTS SHALL BE EQUIPPED WITH PROJECTIONS TO AID IN FASTENING OF FILTER FABRIC.
 - STEEL POSTS MAY NEED TO HAVE A METAL SOIL STABILIZATION PLATE WELDED NEAR THE BOTTOM WHEN INSTALLED ALONG STEEP SLOPES OR INSTALLED IN LOOSE SOILS. THE PLATE SHOULD HAVE A MINIMUM CROSS SECTION OF 17-SQUARE INCHES AND BE COMPOSED OF 18 GAUGE STEEL. AT A MINIMUM, THE METAL SOIL STABILIZATION PLATE SHOULD BE COMPLETELY BURIED.
 - INSTALL POSTS TO A MINIMUM OF 24-INCHES. A MINIMUM HEIGHT OF 1- TO 2-INCHES ABOVE THE FABRIC SHALL BE MAINTAINED, AND A MAXIMUM HEIGHT OF 3 FEET SHALL BE MAINTAINED ABOVE THE GROUND.
 - POST SPACING SHALL BE AT A MAXIMUM OF 6- FEET ON CENTER.
 - INSTALL RUBBER SAFETY CAPS ON TOPS OF STEEL POSTS.

- INSPECTION & MAINTENANCE:**
- THE KEY TO FUNCTIONAL SILT FENCE IS WEEKLY INSPECTIONS, ROUTINE MAINTENANCE AND REGULAR SEDIMENT REMOVAL.
 - REGULAR INSPECTIONS OF SILT FENCE SHALL BE CONDUCTED ONCE EVERY CALENDAR WEEK AND, AS RECOMMENDED, WITHIN 24-HOURS AFTER EACH RAINFALL EVENT THAT PRODUCES 1/2-INCH OR MORE OF PRECIPITATION.
 - ATTENTION TO SEDIMENT ACCUMULATIONS ALONG THE SILT FENCE IS EXTREMELY IMPORTANT. ACCUMULATED SEDIMENT SHOULD BE CONTINUALLY MONITORED AND REMOVED WHEN NECESSARY.
 - REMOVE ACCUMULATED SEDIMENT WHEN IT REACHES 1/3 THE HEIGHT OF THE SILT FENCE.
 - REMOVED SEDIMENT SHALL BE PLACED IN STOCKPILE STORAGE AREAS OR SPREAD THINLY ACROSS DISTURBED AREA. STABILIZE THE REMOVED SEDIMENT AFTER IT IS RELOCATED.
 - CHECK FOR AREAS WHERE STORM WATER RUNOFF HAS ERODED A CHANNEL BENEATH THE SILT FENCE, OR WHERE THE FENCE HAS SAGGED OR COLLAPSED DUE TO RUNOFF OVERTOPPING THE SILT FENCE. INSTALL CHECKS/TIE-BACKS AND/OR REINSTALL SILT FENCE, AS NECESSARY.
 - CHECK FOR TEARS WITHIN THE SILT FENCE. AREAS WHERE SILT FENCE HAS BEGUN TO DECOMPOSE, AND FOR ANY OTHER CIRCUMSTANCE THAT MAY RENDER THE SILT FENCE INEFFECTIVE. REMOVE DAMAGED SILT FENCE AND REINSTALL NEW SILT FENCE IMMEDIATELY.
 - ALL SILT FENCE AND POST MATERIALS SHOULD BE REMOVED AND PROPERLY DISPOSED OF WITHIN 30 DAYS AFTER FINAL STABILIZATION IS ACHIEVED AND ONCE IT IS REMOVED, THE RESULTING DISTURBED AREA SHALL BE PERMANENTLY STABILIZED.

- FABRIC REQUIREMENTS:**
- SILT FENCE MUST BE COMPOSED OF WOVEN GEOTEXTILE FILTER FABRIC THAT CONSISTS OF THE FOLLOWING REQUIREMENTS:
 - COMPOSED OF FIBERS CONSISTING OF LONG CHAIN SYNTHETIC POLYMERS OF AT LEAST 85% BY WEIGHT OF POLYOLEFINS, POLYESTERS, OR POLYAMIDES THAT ARE FORMED INTO A NETWORK SUCH THAT THE FILAMENTS OR YARNS RETAIN DIMENSIONAL STABILITY RELATIVE TO EACH OTHER.
 - FREE OF ANY TREATMENT OR COATING WHICH MIGHT ADVERSELY ALTER ITS PHYSICAL PROPERTIES AFTER INSTALLATION.
 - FREE OF ANY DEFECTS OR FLAWS THAT SIGNIFICANTLY AFFECT ITS PHYSICAL AND/OR FILTERING PROPERTIES. AND,
 - HAVE A MINIMUM WIDTH OF 36-INCHES.
 - USE ONLY FABRIC APPEARING ON SCODOT'S QUALIFIED PRODUCTS LISTING (QPL) APPROVAL SHEET #34, MEETING THE REQUIREMENTS OF THE MOST CURRENT EDITION OF THE SCODOT STANDARD SPECIFICATIONS FOR HIGHWAY CONSTRUCTION.
 - 12-INCHES OF THE FABRIC SHOULD BE PLACED WITHIN EXCAVATED TRENCH AND TOED IN WHEN THE TRENCH IS BACKFILLED.
 - FILTER FABRIC SHALL BE PURCHASED IN CONTINUOUS ROLLS AND CUT TO THE LENGTH OF THE BARRIER TO AVOID JOINTS.
 - FILTER FABRIC SHALL BE INSTALLED AT A MINIMUM OF 24-INCHES ABOVE THE GROUND.

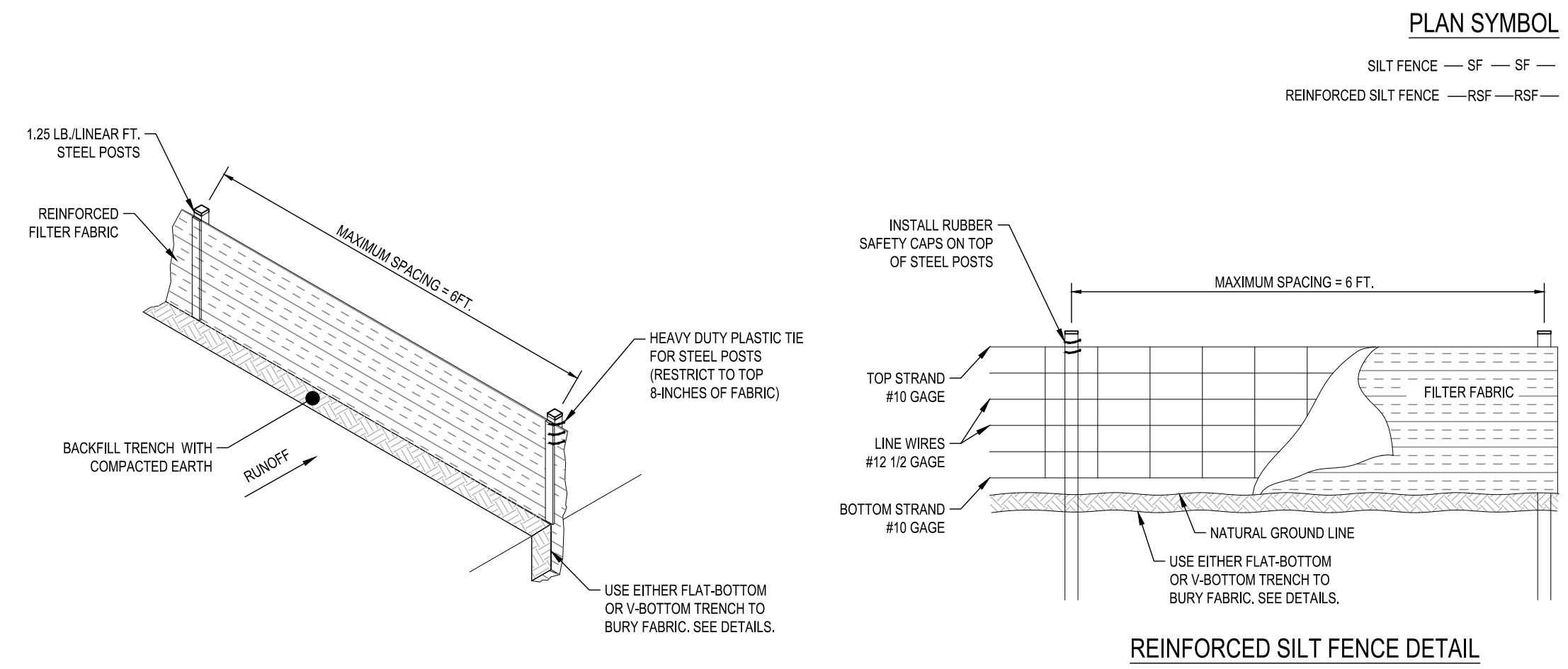

SILT FENCE INSTALLATION

REINFORCED SILT FENCE DETAIL

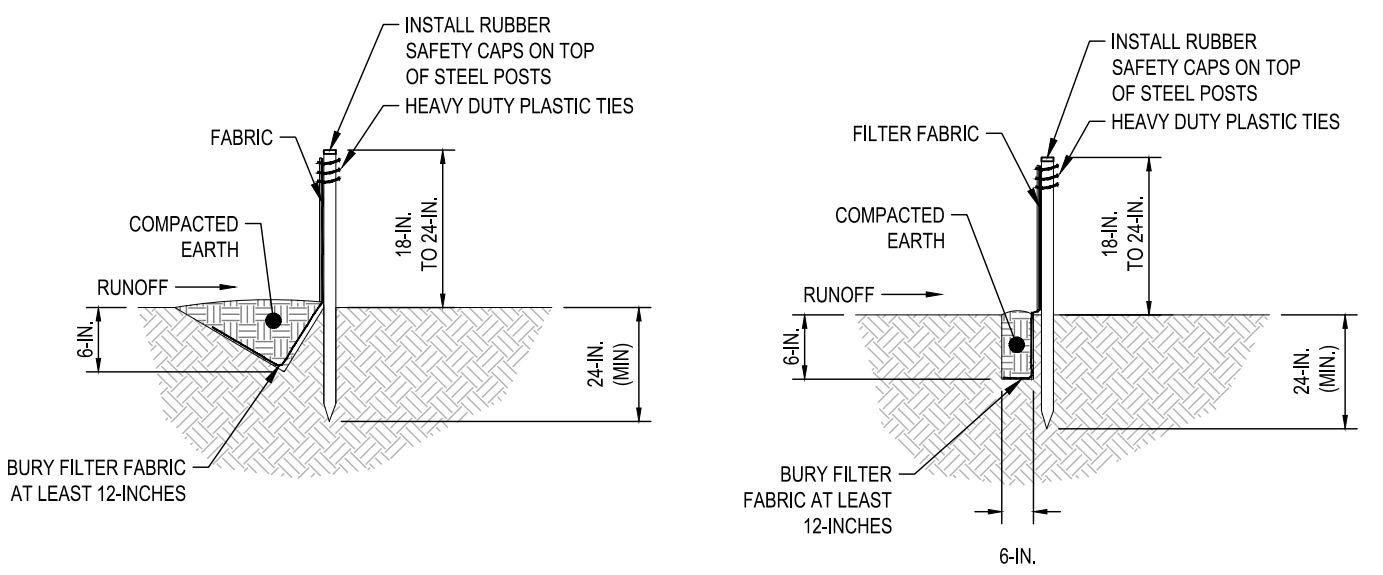

V-SHAPED TRENCH DETAIL

FLAT-BOTTOM TRENCH DETAIL

- REINFORCED SILT FENCE NOTES:**
- WOVEN WIRE FENCE SHALL BE REQUIRED WHERE SPECIFIED AND AS A BACKING FOR FILTER FABRIC WITH AN ELONGATION AS DETERMINED BY ASTM D 1882. OF 50% OR GREATER. THE WIRE FENCE SHALL BE A MINIMUM OF 32 INCHES IN WIDTH AND SHALL HAVE A MINIMUM OF 6 LINE WIRES WITH 12 INCH STAY SPACING.
 - WOVEN WIRE FENCE SHALL BE ATTACHED TO STEEL POST USING THE WIRES. NUMBER AND LOCATION OF FASTENERS WILL BE AS DIRECTED BY THE ENGINEER BUT IN ALL CASES, AFFIXED TO THE POST IN NO LESS THAN FOUR PLACES. THE FILTER FABRIC WILL BE TIED TO THE WOVEN WIRE FENCE AS DIRECTED BY THE ENGINEER IN SUCH A MANNER TO PREVENT SAGGING OR TEARING OF THE FABRIC.
 - WHEN THE TEMPORARY SILT FENCE IS REQUIRED TO RUN NEXT TO AND PARALLEL WITH A CONSTRUCTION FENCE, THE FILTER FABRIC MAY BE ATTACHED TO THE CONSTRUCTION FENCE INSTEAD OF INSTALLING A SEPARATE WOVEN WIRE FENCE.

***THIS DETAIL IS BASED ON SCODOT STANDARD DRAWING NO. SC-03 (FEBRUARY 2014) AND HAS BEEN FORMATTED TO D&F STANDARDS.

SC-03 SILT FENCE
N.T.S.

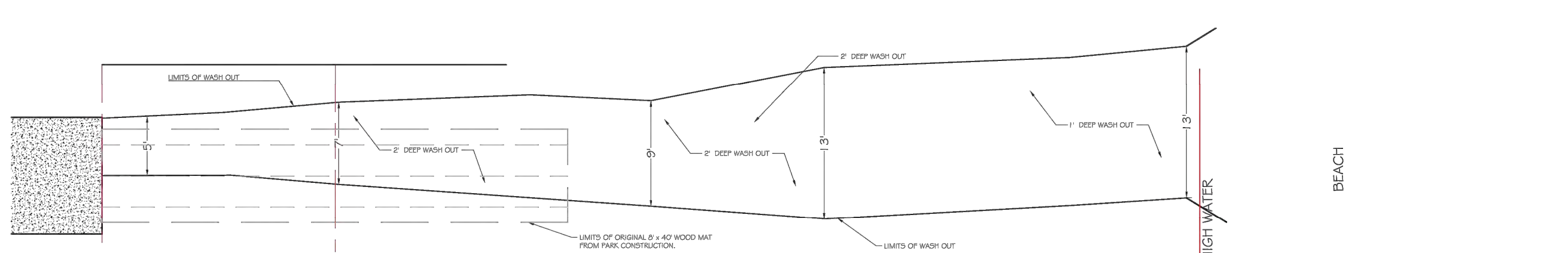

1 PLAN VIEW OF WASHOUT AREA

Scale: 1/8" = 1'-0"

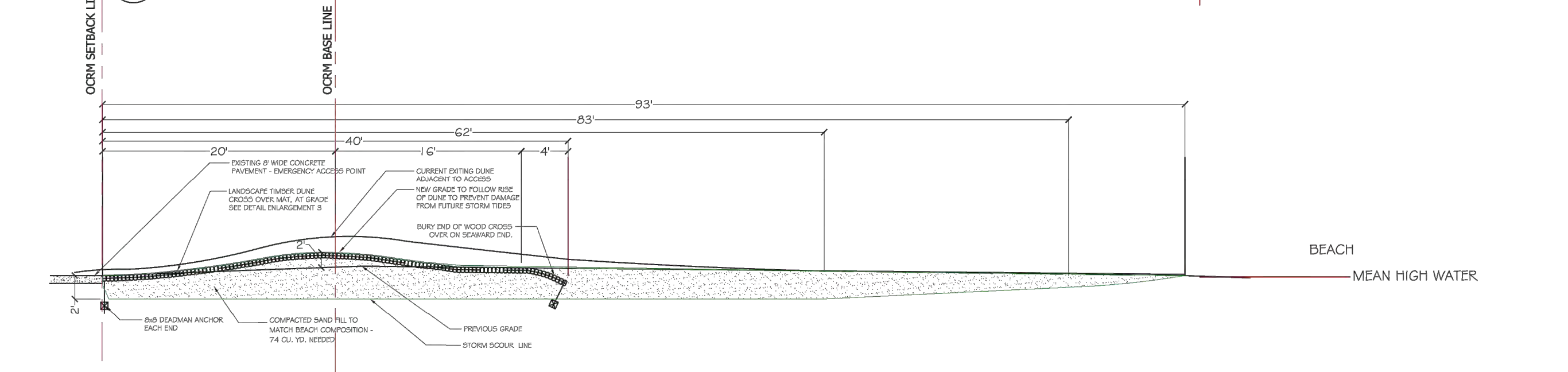

2 SECTION VIEW OF EMERGENCY ACCESS

Scale: 1/8" = 1'-0"

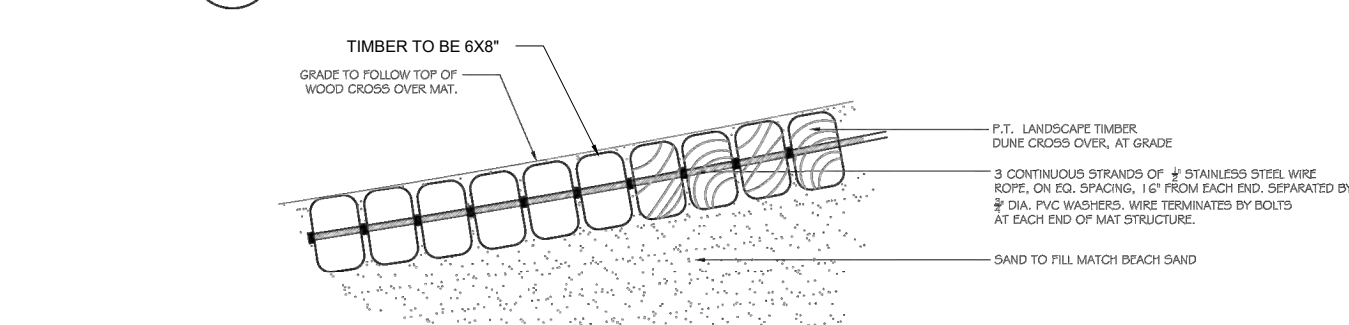

3 DETAIL SECTION WOOD SAND STABILIZER

Scale: 1" = 1'-0"

PREVIOUSLY PERMITTED DETAIL FOR REFERENCE ONLY

Isle of Palms County Park	
Emergency Beach Access	
Scale: as shown	Study Area
December 2015	Sheet 2/2
Charleston County Park & Recreation Commission 461 Silverland Drive, Charleston SC 29402-3173	

ISLE OF PALMS EMERGENCY ACCESS DETAILS

ISLE OF PALMS, SOUTH CAROLINA
SEPTEMBER 2023
32041.00

NOTE: THIS EXHIBIT IS FOR CONCEPTUAL PURPOSES ONLY. NO SURVEY WAS CONDUCTED TO ESTABLISH EXISTING CONDITIONS. THESE DRAWINGS AND THE DESIGN THEREON ARE THE PROPERTY OF DAVIS & FLOYD, INC. AND MAY NOT BE USED IN WHOLE OR IN PART WITHOUT WRITTEN CONSENT OF THE ENGINEER / ARCHITECT AND ANY INFRINGEMENT WILL BE SUBJECT TO LEGAL ACTION.
G:\Jobs\03\32041-00\Production\LandscapeArch_Planning\DWG\32041.00-SITE.dwg, 11/10/2023 1:07:16 PM, Danielle Valdés

EXCEPT FOR MODIFICATIONS SHOWN IN THIS DETAIL, INSTALL TURFSTONE PAVEMENT AND BASE PER EMERGENCY ACCESS DETAIL IN DRAWINGS BY PLANSCAPE/DAVIS & FLOYD DATED 9/26/24

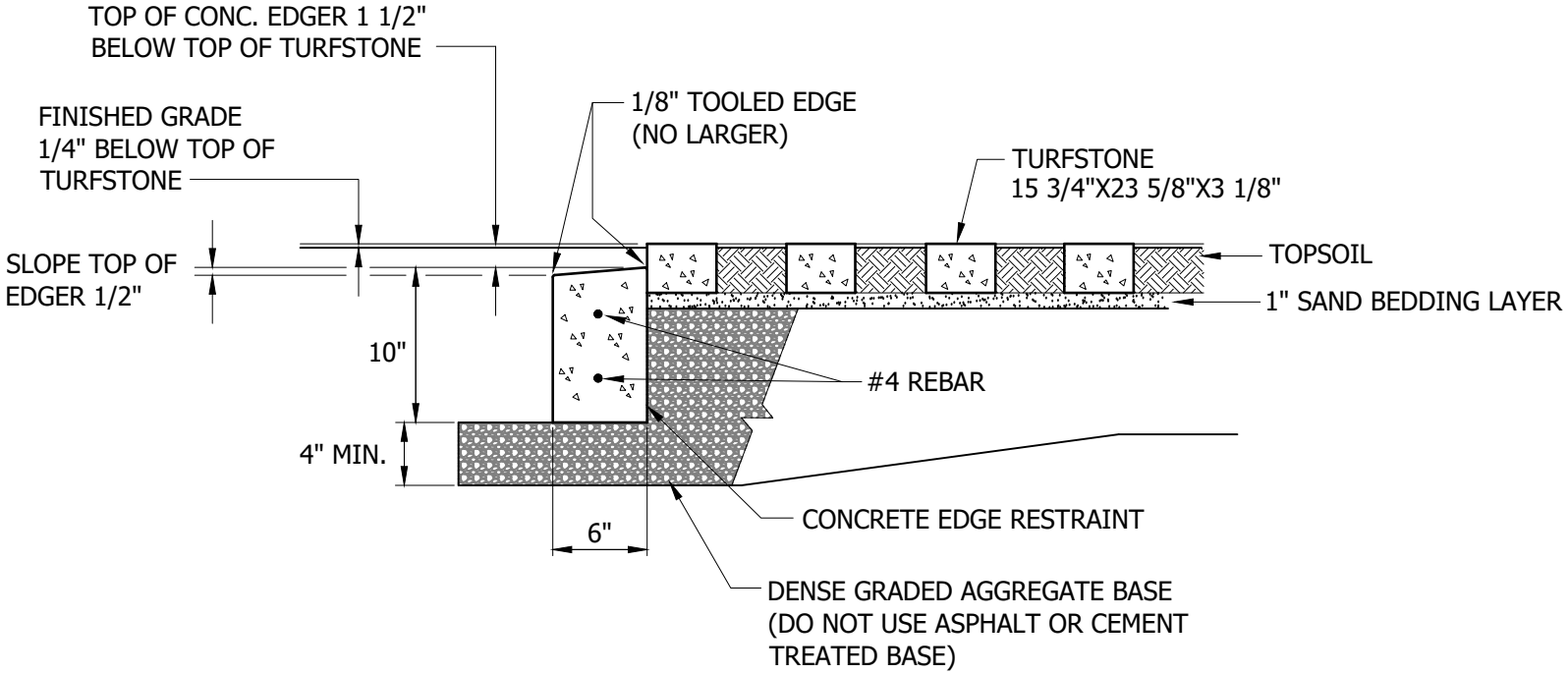

GRAPHIC SCALE

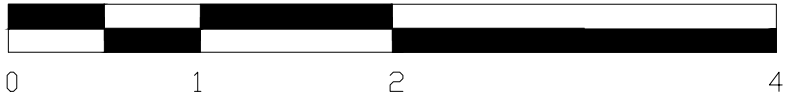

SPECIAL NOTE: USE OF GEOCELL FILLED WITH COMPACTED EXISTING SOIL TO BE EVALUATED AS POSSIBLE ALTERNATIVE TO DENSE GRADED AGGREGATE BASE

